



HBJC501F797-Q37-B Series

Intel® LGA1151 CPU, DDR4 2400/2666MHz up to 64GB



1. Fanless Black Aluminum Enclosure
2. Support Intel LGA1151 Coffee Lake Processors
3. Supports DDR4 2400/2666MHz SODIMM up to 64GB
4. Supports up to 3 Displays, 1* HDMI, 2* DP
5. 1* 2.5" SATAIII 6Gb/s Internal Drive bay
6. 1* M.2(M-key, 2242/2260/2280, Support NVMe) slot for SSD
7. Support onboard TPM 2.0



External I/O

Rear

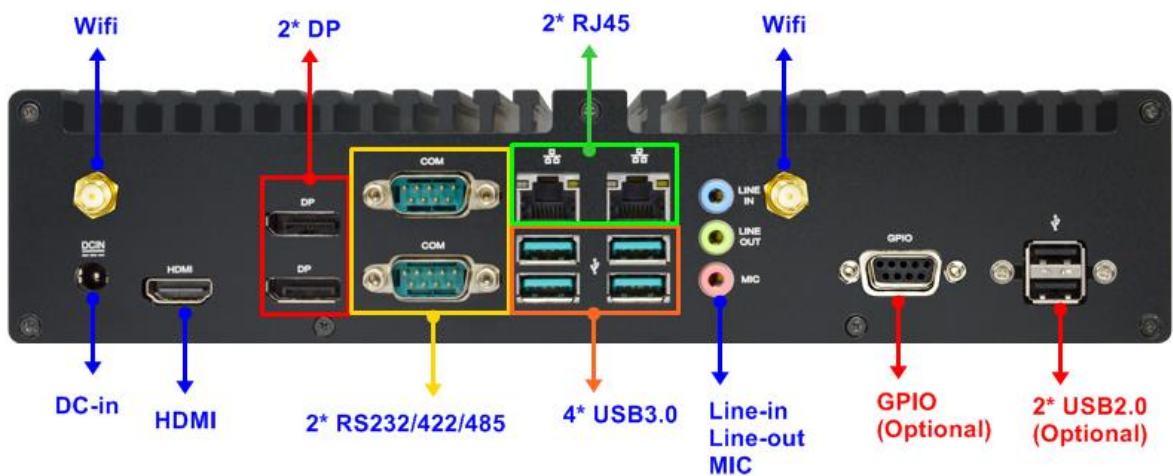

Front

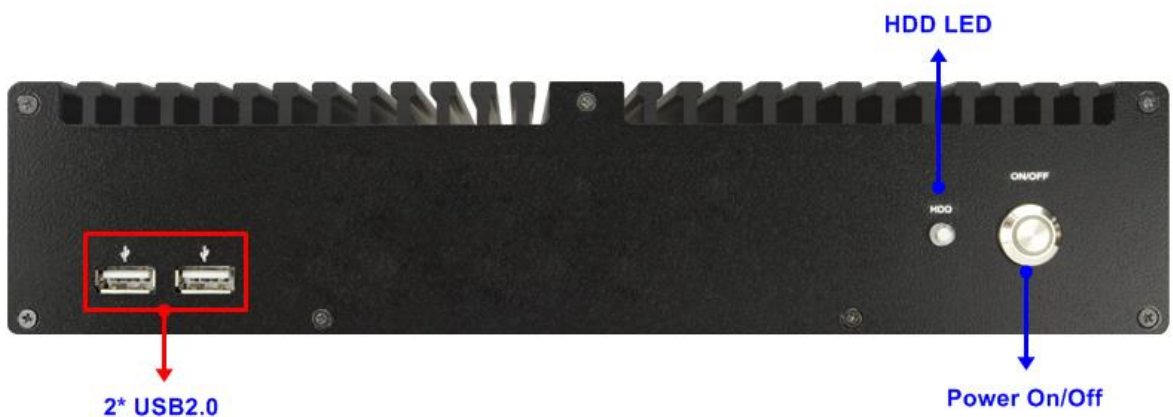

Specifications

MB Model	JNF797-Q370 Series/ MINI-ITX
Part No	<ul style="list-style-type: none"> ● HBJC501F797-Q37-B (non-WIFI) ● HBJC501F797I-Q37-B (WIFI)
BIOS	AMI SMT Flash ROM
CPU/Chipset	<ul style="list-style-type: none"> ● Intel® LGA1151 Coffee Lake Processor (Max. TDP 35W) ● Intel® Q370 chipset <p style="color: #e67e22; font-size: small;">Notes: When the system runs, CPU will automatically adjust its working clock frequency according to changing workload.</p>
Memory	2 * SO-DIMM slots / Dual channel DDR4 2400/2666MHz up to 64GB total
Storage	<ul style="list-style-type: none"> ● 1 * 2.5" SATAIII 6Gb/s internal drive bay (only support 2.5" HDD with a height ≤ 10mm) ● 1 * M.2 (M-key, 2242/2260/2280, Support NVMe) slot for SSD
Network	<ul style="list-style-type: none"> ● 2 * Intel GbE (i219LM, i211AT) ● 1 * M.2(E-key, 2230) slot for WIFI expansion module
Rear Panel I/O	<ul style="list-style-type: none"> ● 4 * USB 3.1 ports (Gen. 2) ● 1 * HDMI (Max. Resolution: 4096 x 2160@30Hz) ● 2 * DP (Max. Resolution: 4096 x 2304@60Hz) ● 2 * RJ45 ● 1 * Audio (Line-in, Line-out, MIC) ● 2 * COM (RS232/422/485) ● 2 * Antenna holes (HBJC501F797I-Q37-B only) ● 1 * DC-in jack
Front Panel I/O	<ul style="list-style-type: none"> ● 1 * Power button, 1 * HDD LED ● 2 * USB 2.0 ports
Internal Expansion	Support onboard TPM 2.0
Power Source	AC to DC Adapter 19VDC-6.3A 120W
Compliance	CE, FCC, LVDS, RoHS, ErP Ready
Environment	<ul style="list-style-type: none"> ● Operating Temperature: -20 ~ 50 °C (The test environment is closed and windless) ● Storage Temperature: -10 ~ 70 °C ● Humidity: 90%, non-condensing
Dimensions	264 (W) x 199.4 (D) x 58 (H) mm
Packing	<ul style="list-style-type: none"> ● Net Weight: 4.2KG ● Gross Weight: 5KG ● Color Box dimension: 406 (W) * 148 (D) * 380 (H) mm
OS Support	Windows 10, Linux
Warranty	2 Years limited warranty

*Specifications subject to change without notice, not responsible for typographical errors. Does not include HDD or OS.

Product coding principle



Mechanical Drawings (Unit = mm)

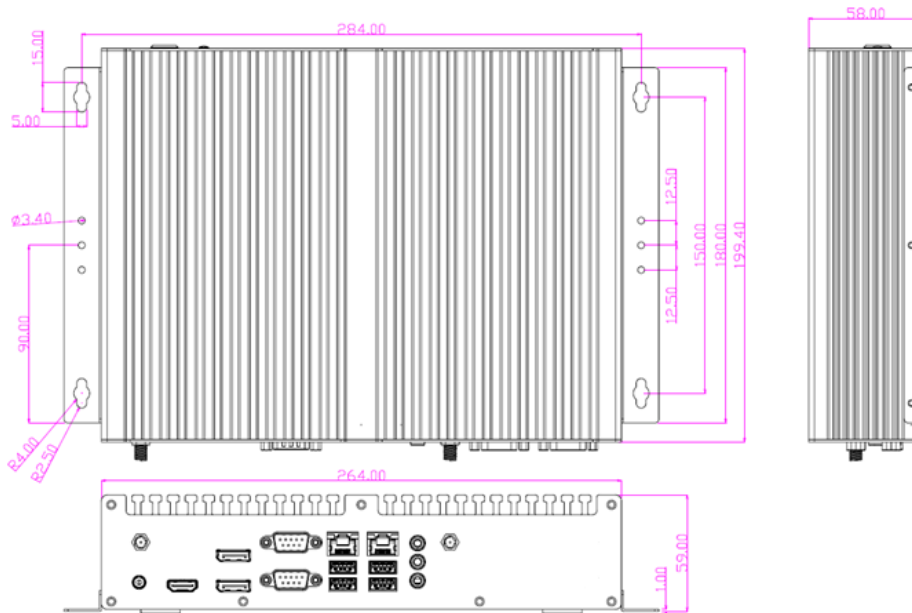

Accessories

Parts Number	Description
-----	HBJC501F797 SERIES
L01AS056-F	Adapter 19V/6.32A 120W
Change according to shipping area	Power cord
HCS5XXMWM01B-F	JC5XX Wall mount / Black color
LCSCHBJC3XX-F	Screw pack
J05-ANT-GX55240-F	Antenna 2.4G -2.2dBi GX552400001SM (HBJC501F797I-Q37-B only)
HCS3XXDINRAILPS-F	Din Rail Clip